



UpLift Lite

3250 c+v, 3500 c+v, 3700 c+v, 3875 c+v

Installing your TV and equipment

Thank you for choosing UpLift TV Lift Cabinets. This lift is designed to support TV's with a maximum weight of 80 lbs.

Be sure all parts are included and undamaged. If any hardware is damaged or missing, contact customer service at 1-888-5-UPLIFT. Never use damaged parts.

Do not return damaged hardware, parts, or equipment to the retailer. Simply contact customer service and replacement parts will be overnighted directly to you.

WARNING

This product contains small items that could be a choking hazard if swallowed. Keep these items away from young children!

CAUTION

Do not use this product for any purpose not explicitly specified by UPLIFT. Improper assembly may cause property damage or personal injury. If you do not understand with these directions, or have doubts about the safety of the assembly, contact Customer Service or call a qualified contractor. UPLIFT is not responsible for damage or injury caused by incorrect assembly or use.

UpLift TV Cabinets
40 SE 7th St., Boca Raton, FL 33432
Customer Service: 1-888-5-UPLIFT

Supplied Parts and Hardware

Before starting assembly, verify all parts are included and undamaged. If any parts are missing and damaged, do not return the item to the retailer; contact Customer Service.

Never use damaged parts.

TV Mounting Hardware located on the TV Mounting Bracket Contains:

2 pcs. of TV plastic caps

2 pcs. of TV plastic washers

2 pcs. of M8X40

2 pcs. of M8X25

2 pcs. of M6X30

2 pcs. of M5X30

2 pcs. of M4X30



2x

(TV Plastic Cap)

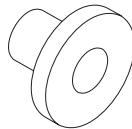

2x

(TV Plastic Washer)

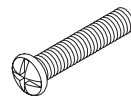

2x

(M8X40)

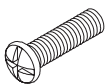

2x

(M8X25)



2x

(M6X30)



2x

(M5X30)



2x

(M4X30)

1: Plug Lift to Wall

(For additional installation support, visit our web site
and videos at www.Upliftcabinets.com)

- A) Pull the power cord out of one of the two holes in the back of the cabinet. Choose the exit hole that will be nearest your wall outlet.

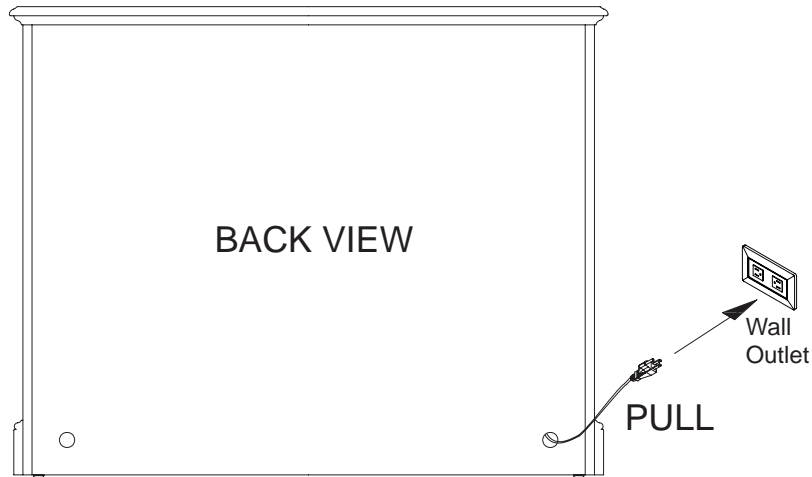
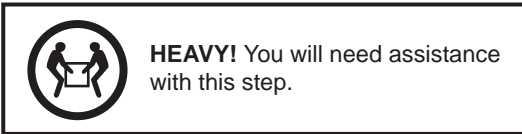

Fig. 1

- B)



Using two people, slide the cabinet into place.

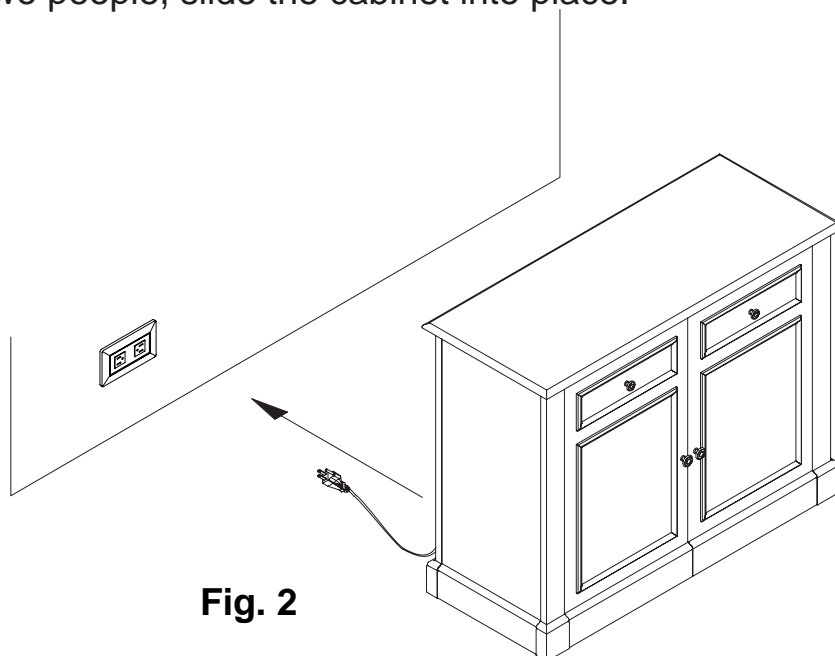
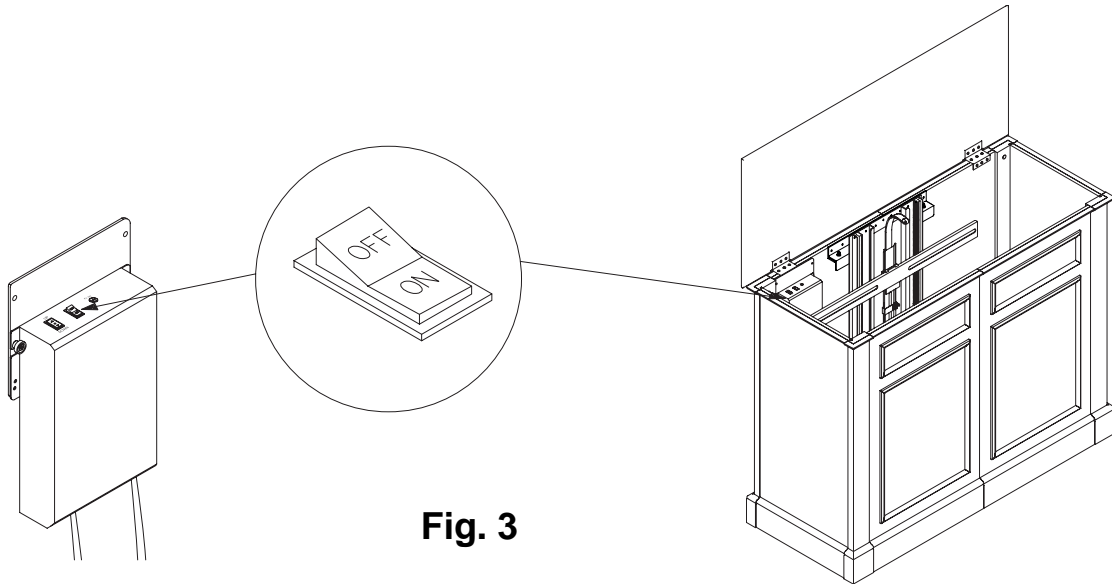

Fig. 2

2: Raise Lift

- A) Turn power on by toggling the switch to the ON position.



- B) Using the remote, press and release the UP button on the remote control unit.

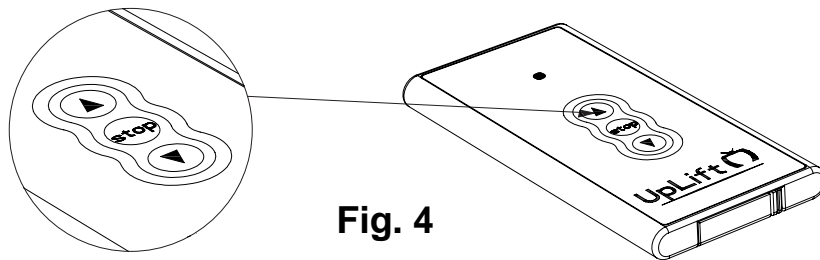

- C) With lift completely in the up position, turn the lift OFF on the manual control box.

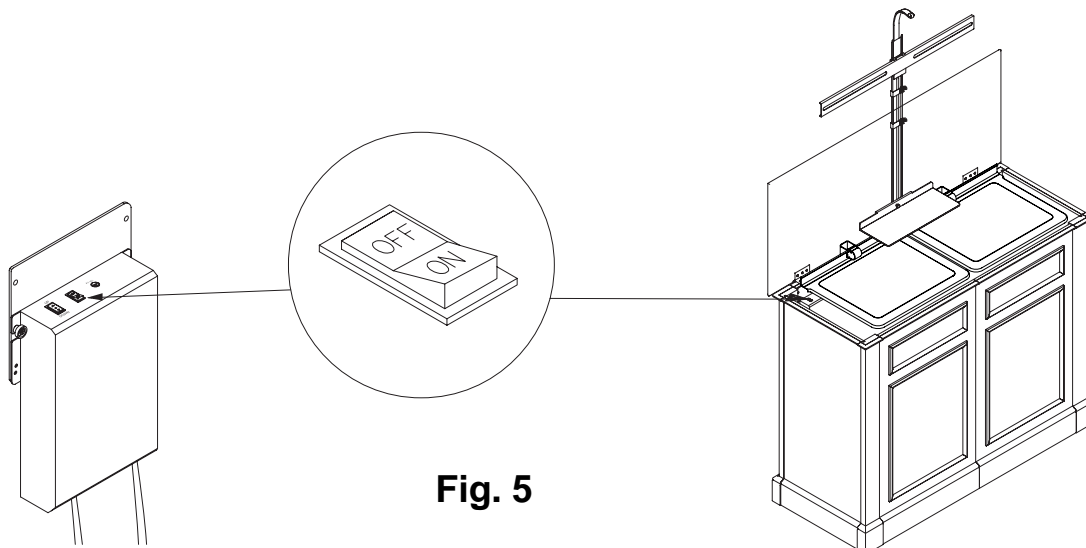

3: Mounting Your TV

- A) Remove the stand from your TV.
- B) Measure the overall height of your TV without the stand.

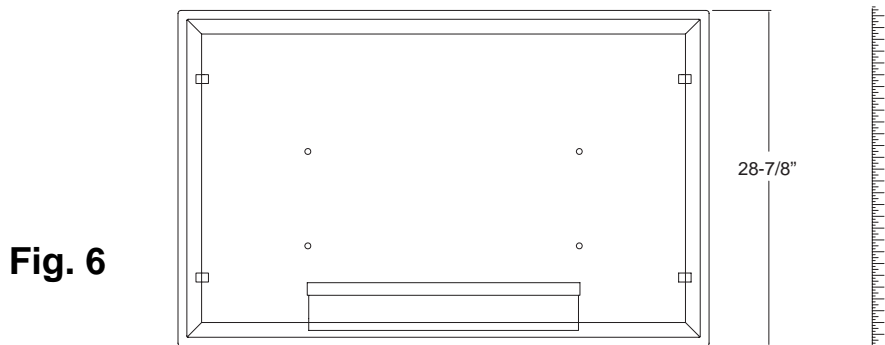

- C) Adjust “vertical push arm” to the measurement calculated in “B” + add 3/4” by loosening the three thumb bolts, raising to position and tightening. This will allow the “push arm” to sit just above your TV.

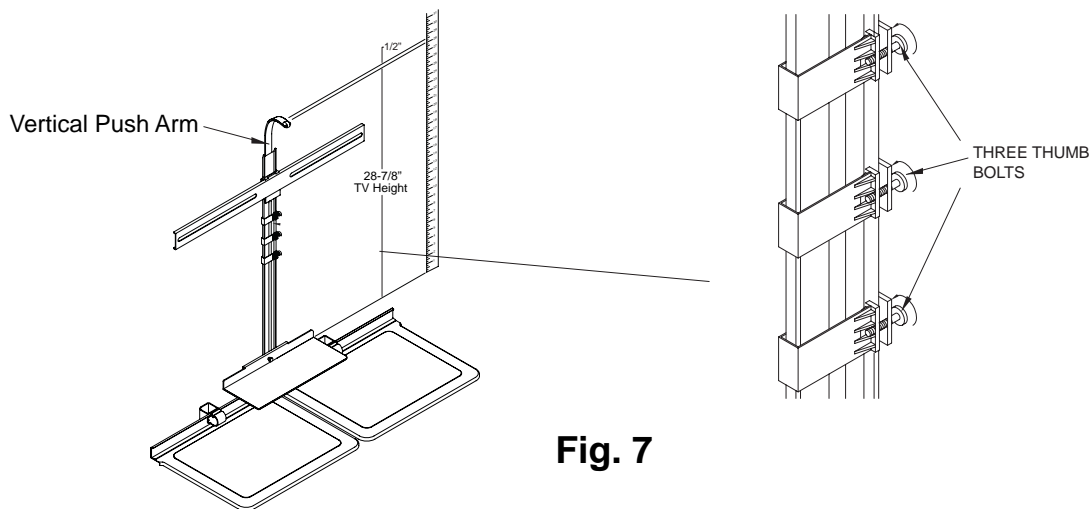

- D) Measure the distance from the bottom of your TV to the middle of the threaded inserts on the back of your TV.
Note: Use the top two threaded inserts and not the bottom.

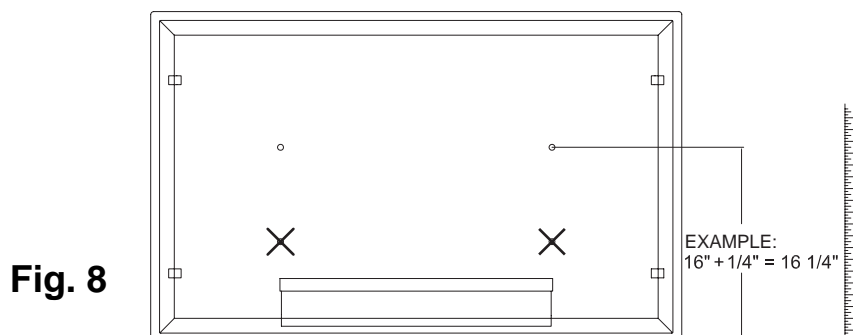

- E) Add 1/4” to that dimension.

F) Adjust horizontal mounting bracket to the measurement calculated in “E” by manually raising or lowering the horizontal TV bracket. Your measurement should be from the small TV platform to the center of the slot on the TV bracket as shown in Fig. 9.

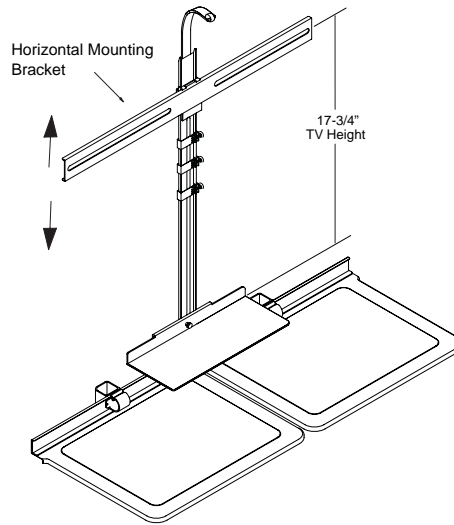

Fig. 9

G)



HEAVY! You will need assistance with this step.

Using two people, place TV on platform and attach to bracket using the supplied plastic caps, washers, and bolts.

⚠ WARNING

You should not feel resistance when threading bolts into the back of the televisions. If you feel resistance, stop immediately and call Customer Service.

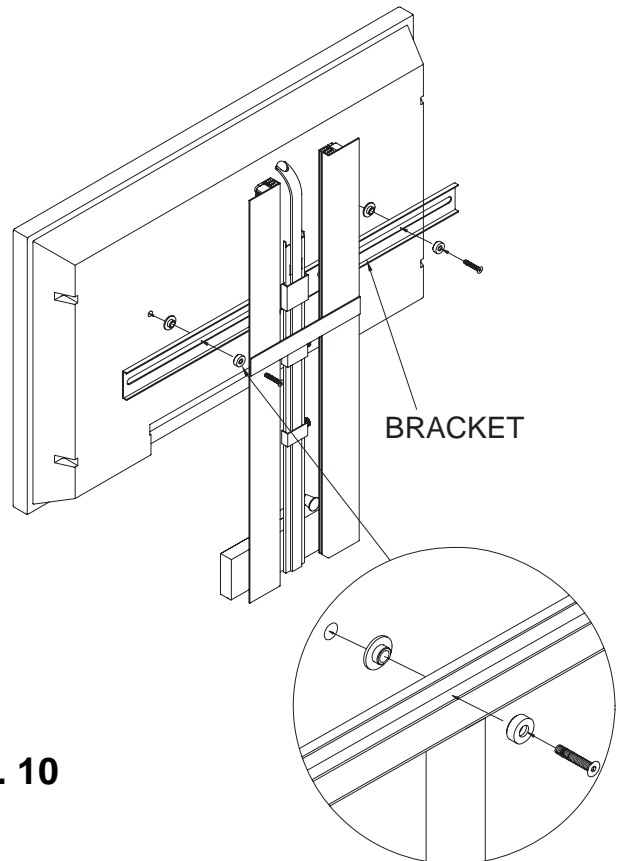
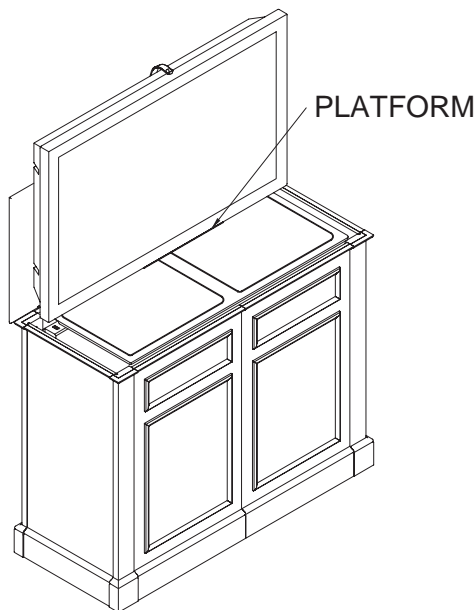

Fig. 10

H) Plug TV into any of the three outlets located on the manual control box.

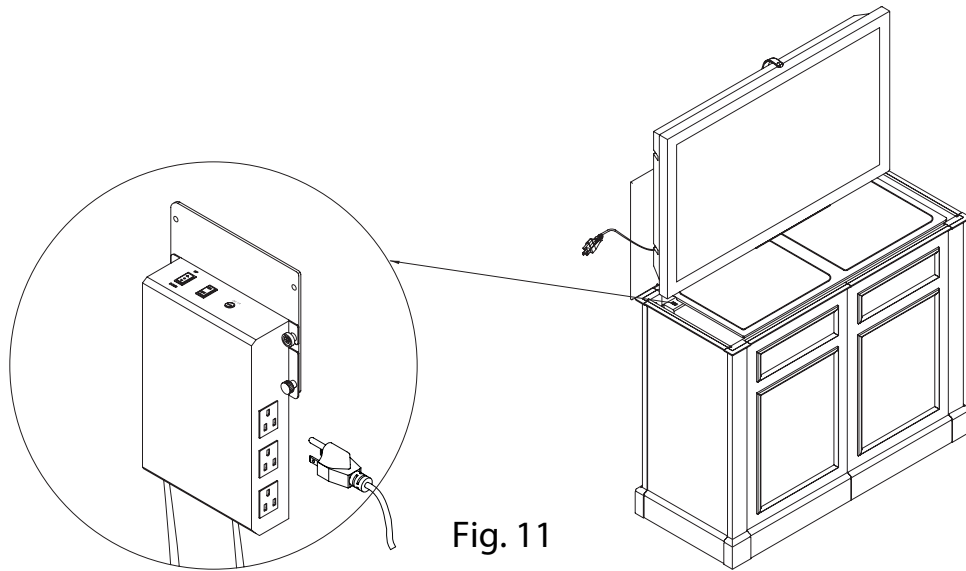

Fig. 11

I) Run the TV's power cord through one or both of the horizontal wire management clips. If your power cord is on the left (Fig.12A), use the left clip only. If the cord is on the right side, use the left and right clip (Fig. 12B).

⚠ WARNING

You must leave enough slack in the wire to allow the lift to travel up and down without pulling on wire.

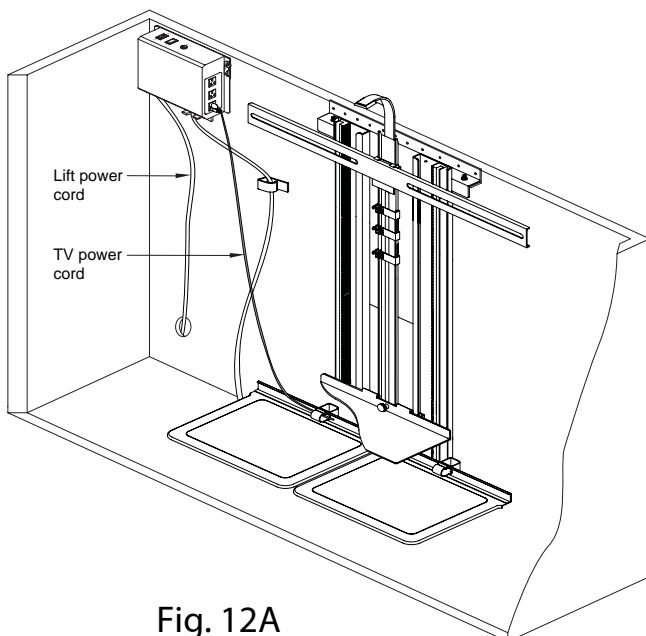

Fig. 12A

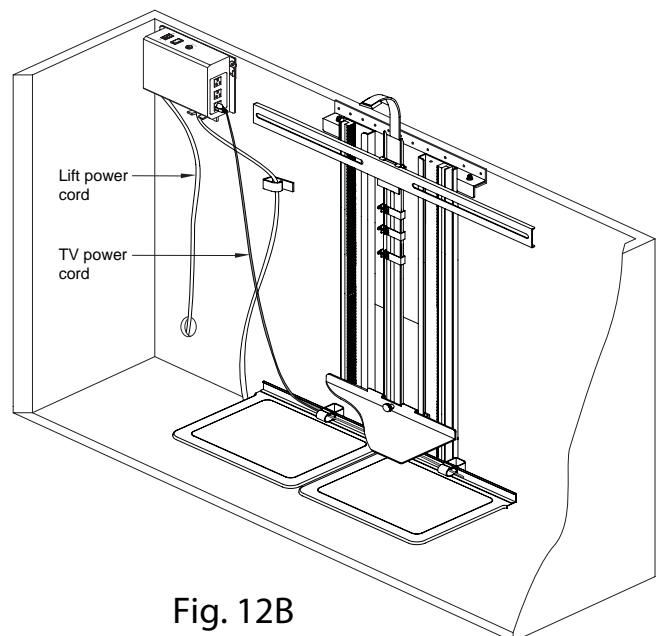
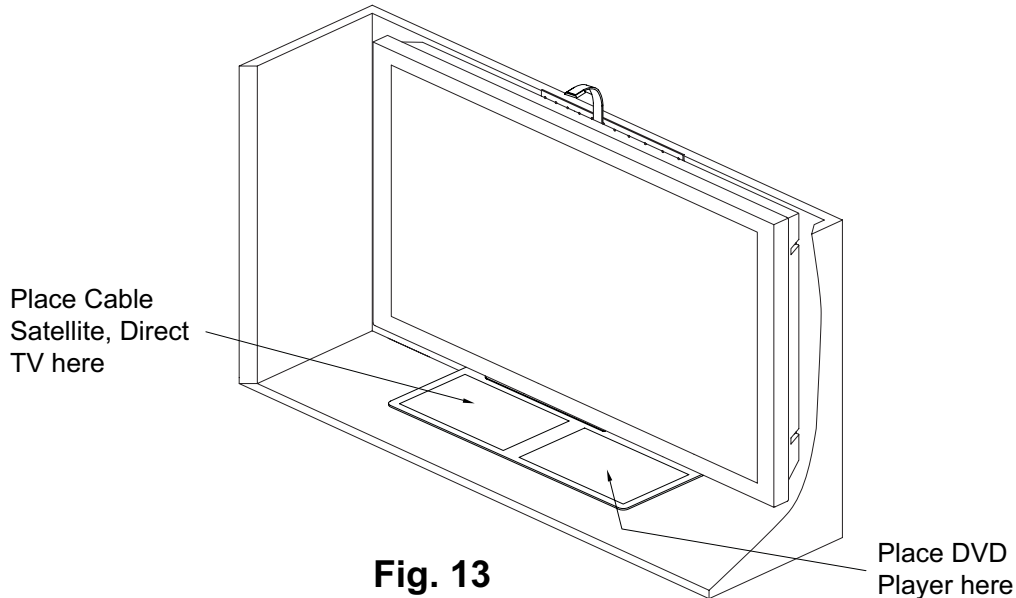

Fig. 12B

4: Installing Your Components

- A) Place your equipment in the following position on the platform as per Fig. 13.



- B) Run your cables and wires through the horizontal wire management clips as per Fig 14.

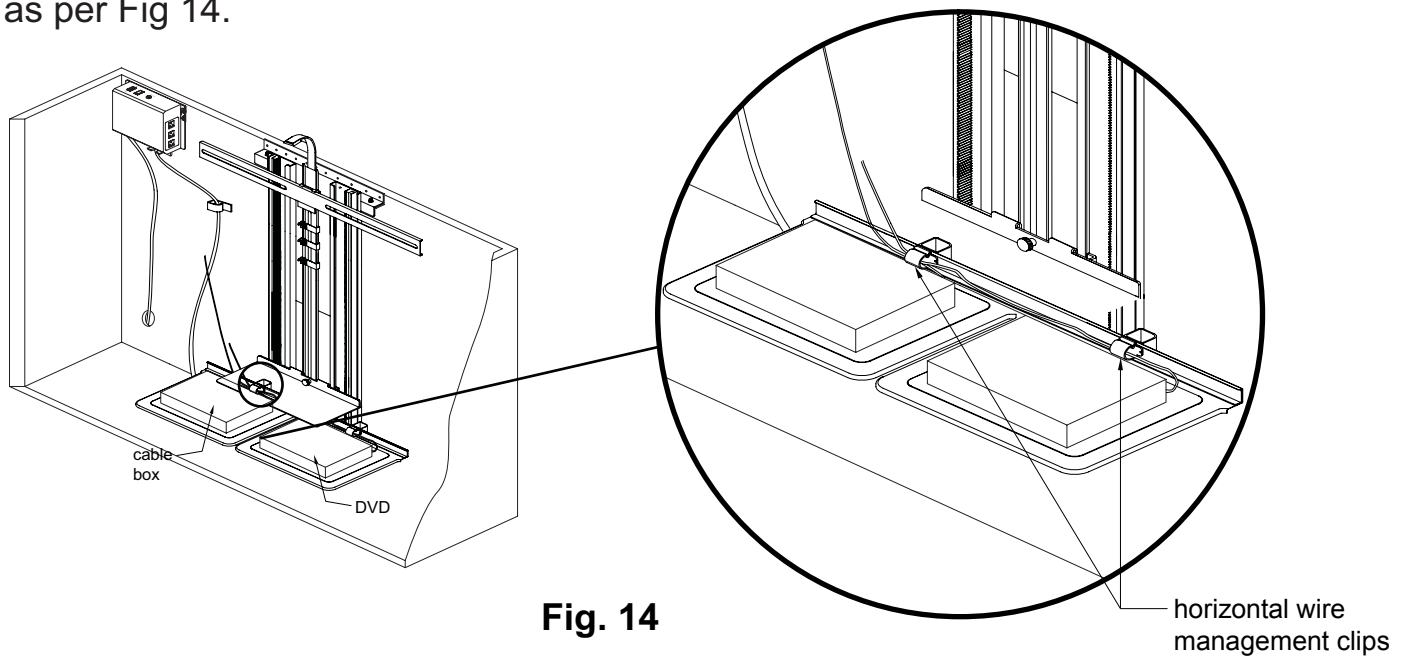

⚠ WARNING

Be sure that all cables and wires have a minimum of 37" of slack to allow the lift to go up and down otherwise the cords will be pulled and damage will occur.

- C) Run all coaxial cables and wires that exit the cabinets back panel through the vertical wire management clips.

⚠ WARNING

Do not run these cables/wires through the horizontal wire management clips.

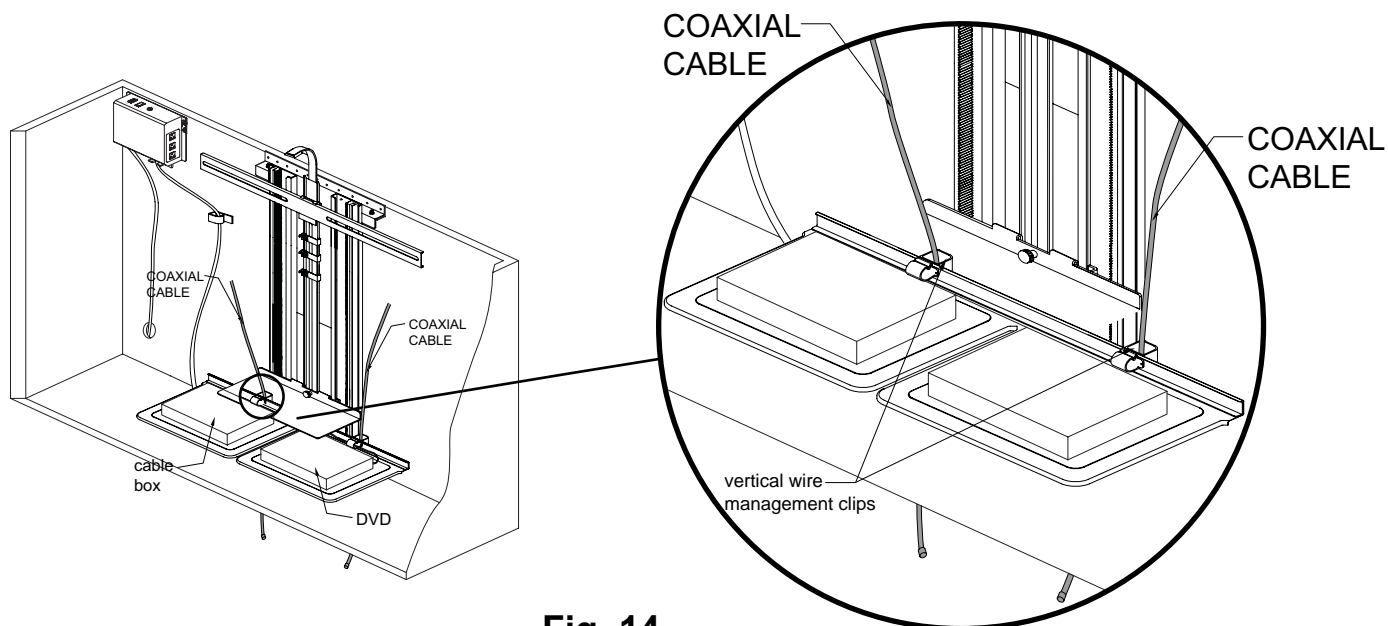

Fig. 14

- D) Run all wires out of the cord exit hole in the back of the cabinet.

⚠ CAUTION

Do not route cables so that they can become entangled with the lift machine.

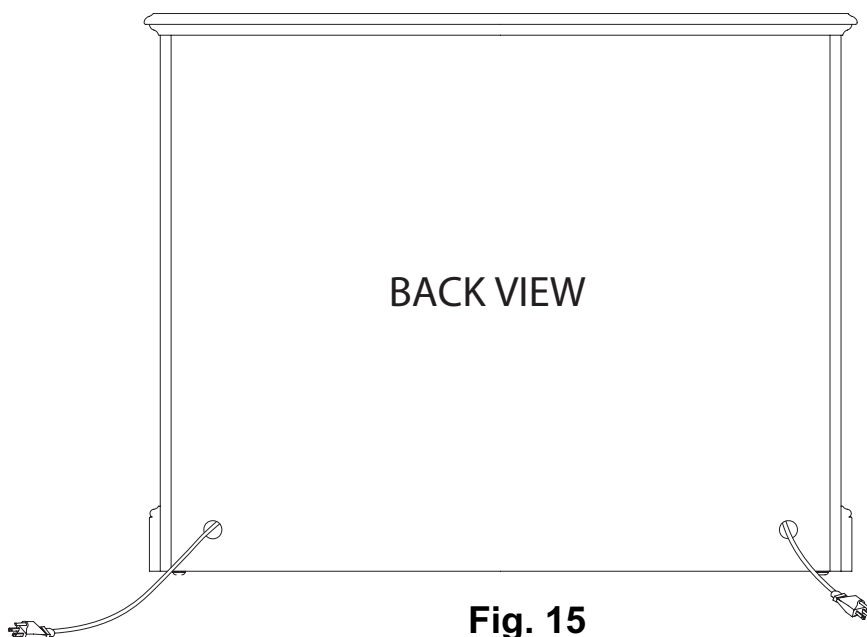
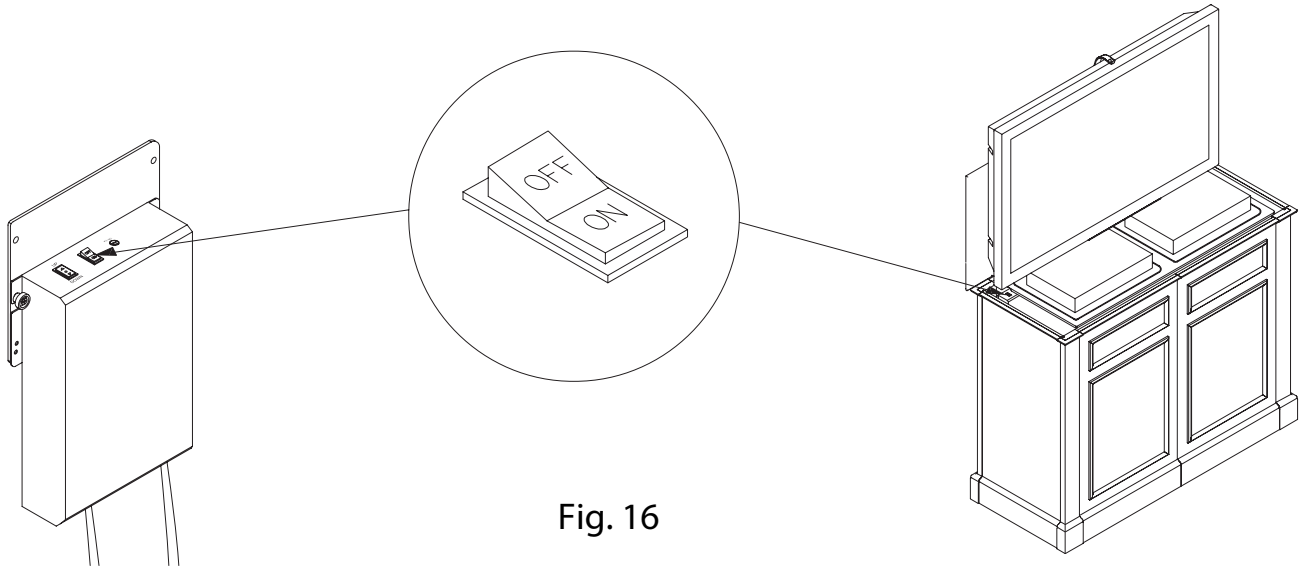

Fig. 15

5: Operating Lift

- A) Turn lift on by toggling manual control switch to the ON position (Fig. 17).



- B) Using the manual controls, run the lift down into the cabinet (Fig. 18).

⚠ CAUTION

Watch carefully to see that all wires and cords are not rubbing on the lift and or cabinet and that they are not being pulled. Use the two wire management clips as needed to keep wires from being tangled or entrapped.

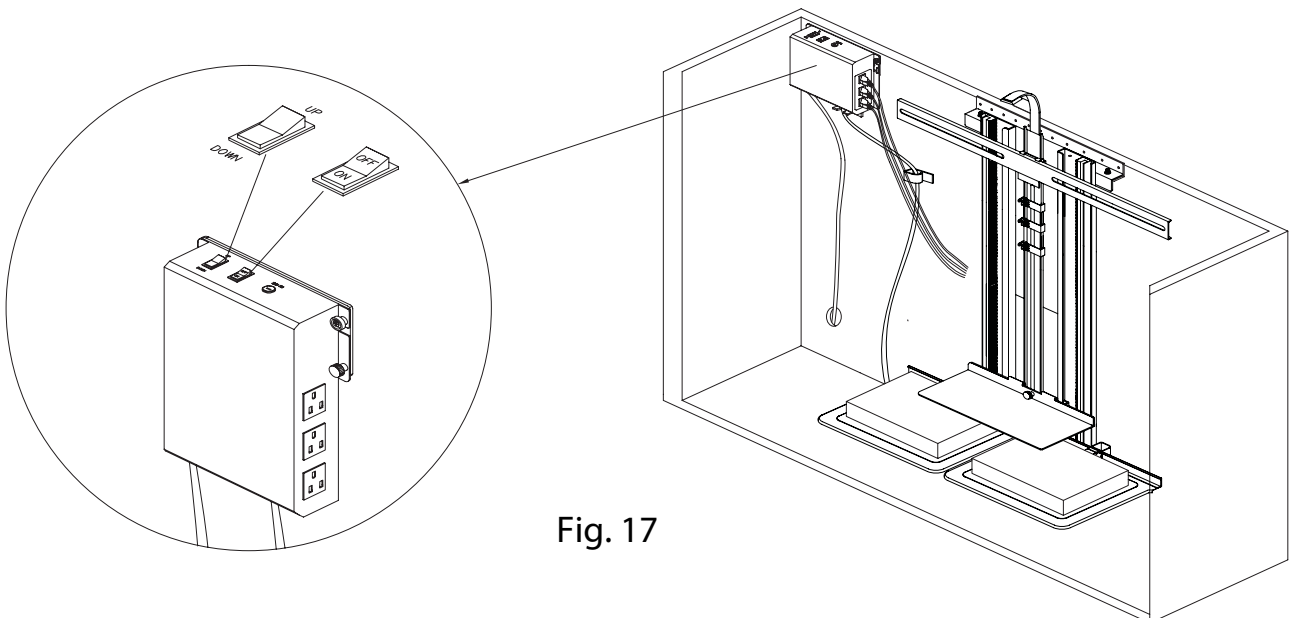

C) If the TV appears to be crooked, you can make fine adjustment to level it.

Step 1: Loosen the top center plastic bolt (do not remove)

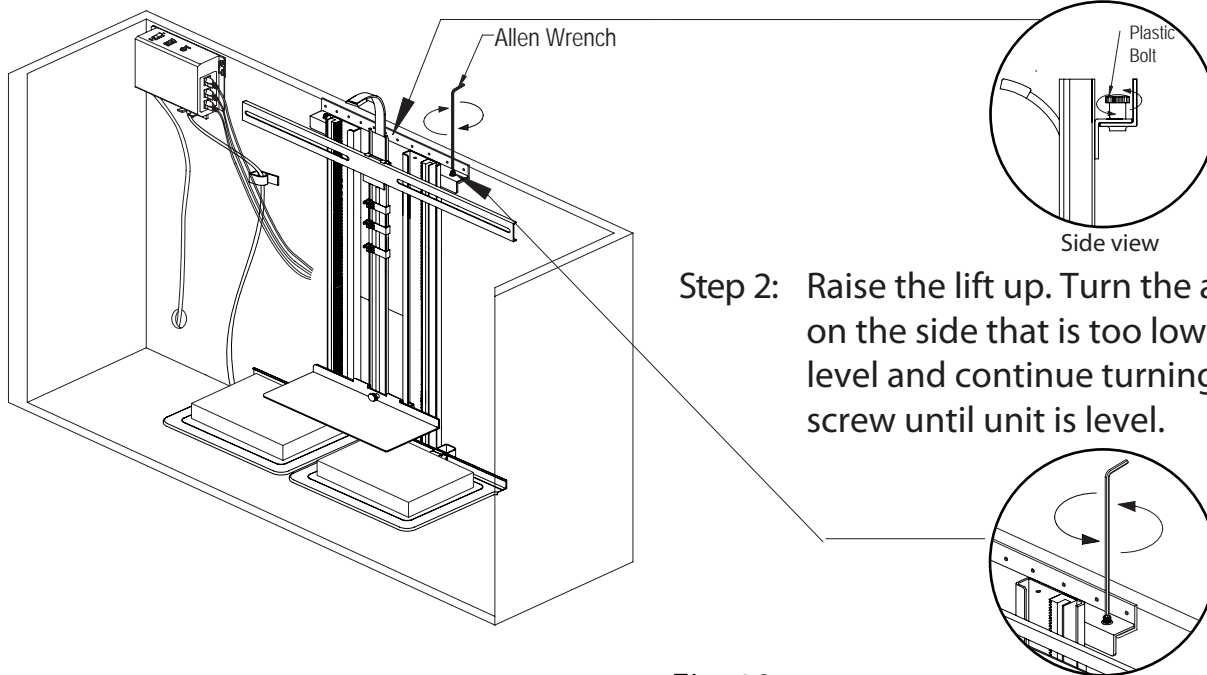

Step 2: Raise the lift up. Turn the allen clockwise on the side that is too low. Check for level and continue turning the allen screw until unit is level.

Fig. 18

Syncing Your Remote Control

If the manual up/down switches are operating your lift but the remote control is not, your remote has likely lost its connection to the lift. This can be corrected by syncing your remote with the lift as follows:

- Drive the lift into the down position.
- Turn the lift off on the manual control box.
- Leave the lift off for 60-90 seconds minimum.
- After 60-90 seconds has expired, press and hold the up button on the remote control. The red light on the remote should stay on.
- Keeping the remotes up button depressed, turn the lift on.
- After 2-5 seconds, the lift should begin running up.
- Release the up button as soon as the lift begins to move.

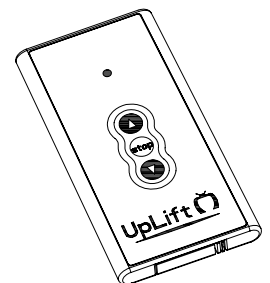

Questions? Call us at 888-5-UPLIFT